

# DELUXE BARREL STOVE KIT

## Model BK150E Owners Manual

(save this manual for future reference)



*(kit does not include barrel)*

*For use with 30 – 55 gallon closed head-style steel barrels only.*

NOTE: A PROFESSIONAL, LICENSED HEATING AND COOLING CONTRACTOR SHOULD BE CONSULTED IF YOU HAVE QUESTIONS REGARDING THE INSTALLATION OF THIS SOLID FUEL BURNING APPLIANCE.

READ ALL INSTRUCTIONS CAREFULLY BEFORE STARTING THE INSTALLATION OR OPERATING THE STOVE. FAILURE TO FOLLOW INSTRUCTIONS MAY RESULT IN PROPERTY DAMAGE, BODILY INJURY, OR EVEN DEATH.

SAFETY NOTICE: IF THIS STOVE IS NOT PROPERLY INSTALLED, A HOUSE/BUILDING FIRE MAY RESULT. FOR YOUR SAFETY, CONTACT LOCAL BUILDING OR FIRE OFFICIALS ABOUT PERMITS, RESTRICTIONS, AND INSTALLATION REQUIREMENTS FOR YOUR AREA.

*Double Barrel Stove Kit BK50E  
(does not include barrels)*



*For use with 30 – 55 gallon closed head-style steel barrels only.*

DO **NOT** INSTALL THIS STOVE IN A MOBILE HOME, MANUFACTURED HOME, TENT, OR TRAILER – **NO EXCEPTIONS!**

NOTE: THIS STOVE IS **NOT** A UL LISTED STOVE.

# VOGELZANG

*International* CORPORATION



Vogelzang International Corporation  
400 West 17th Street  
Holland, Michigan 49423  
www.vogelzang.com  
Phone: 1-616-396-1911  
Fax: 1-616-396-1971

## **SAFETY INSTRUCTIONS . . . . . Read All Instructions Carefully.**

1. The installation of this barrel stove kit must comply with your local building code rulings. While assembling, always wear ANSI approved safety goggles and protective gloves. Use a file grinder to remove any sharp edges from holes cut in the barrel. **DO NOT USE A TORCH** to cut barrel openings. Volatile gasses may be trapped inside and explosion could result.
2. Use only new or reconditioned closed head-style, steel barrels of 30 gal. min. & 55 gal. max. size. Do not use a rusted barrel or one that is contaminated with residual toxic chemicals or volatile gases. Do not install more than one heat-exchange barrel over combustion barrel.
3. Verify that the stove is properly installed before firing the stove for the first time. After reading these instructions, if you have any doubt about your ability to complete your installation properly, you must obtain the services of a professional licensed installer familiar with all aspects of safe and correct installation. **DO NOT** use temporary or makeshift compromises during installation. There must be **NO DEVIATION OR ALTERATION OF ANY KIND** from the very specific instructions spelled out in this instruction manual as it pertains to the installation of this woodstove. **NO EXCEPTIONS!**
4. **WARNING: RISK OF FIRE.** DO NOT store wood, kindling, flammable liquids or other combustible materials in the vicinity of the appliance. Do not place fuel, furniture or any other objects within the clearance area. Refer to reference figures 3–5 in this manual.
5. **DO NOT INSTALL THIS STOVE IN A MOBILE HOME, MANUFACTURED HOME, TRAILER OR TENT NO EXCEPTIONS! (HUD Federal Standard: 24 CFR Ch.XX).**
6. **DO NOT ELEVATE THIS STOVE BY ANY MEANS.** (i.e. bricks under legs, cement blocks) Stove legs must set directly upon the solid-surface non-combustible floor as specified in this stove instruction manual.
7. **DO NOT MODIFY THIS STOVE IN ANY WAY!** Stove must be installed with legs provided, attached as shown in the instructions. Assemble only with original parts as supplied and shown in this manual. **DO NOT OPERATE A STOVE THAT IS MISSING ANY PARTS!** If any parts are missing or defective, please notify the dealer or manufacturer immediately. Replace missing, broken or worn parts with factory original or equivalent parts only.
8. Do not tamper with combustion air control beyond normal adjustment capacities.
9. Always connect this stove to a chimney and vent the outside. Never vent to another room or inside a building. **DO NOT CONNECT THIS UNIT TO A CHIMNEY FLUE SERVING ANOTHER APPLIANCE.**
10. **DO NOT CONNECT A WOOD BURNING STOVE TO AN ALUMINUM TYPE B GAS VENT.** This is not safe. Use approved masonry or an Underwriters Laboratories Listed UL 103 HT Residential Type and Building Heating Appliance Chimney. Use a 6"/152mm diameter chimney, that is high enough to give a good draft. (See specifics in Chimney Connections instructions).
11. Be sure that your chimney is safely constructed and in good repair. Have the chimney inspected by the fire department or a qualified inspector. Your insurance company should be able to recommend a qualified inspector. Chimney connector pipe must be in good condition. Replace if necessary before using stove.
12. **WARNING: RISK OF FIRE.** Creosote or soot may build up in the chimney connector and chimney and cause a house/building fire. Inspect the chimney connector and chimney twice monthly during the heating season and clean if necessary. (see Service Hints section in this manual).
13. In the event of a chimney fire, turn the air control and flue damper to closed position, leave the building and **CALL THE FIRE DEPARTMENT IMMEDIATELY!** Have a clearly understood plan on how to handle a chimney fire by contacting your local fire authority for information on proper procedures in the event of a chimney fire. After the fire is out, the chimney must be cleaned and inspected for any stress or cracks before starting another fire. Check the condition of any combustibles surrounding the chimney.
14. **DISPOSAL OF ASHES**  
Ashes should be placed in a steel container with a tight fitting lid and moved outdoors immediately. The closed container of ashes should be placed on a noncombustible floor or on the ground, well away from all combustible materials, pending final disposal. If the ashes are disposed of by burial in soil or otherwise locally dispersed, they should be retained in the closed container until all cinders have completely cooled. Other waste shall not be placed in this container.
15. Ashes should not be allowed to accumulate to a height such that they block the spin draft openings.
16. To prevent injury, do not allow anyone to use this stove who is unfamiliar with the correct operation of the stove.
17. Do not operate stove while under the influence of drugs or alcohol.
18. The special paints used on your kit parts may give off some smoke and an odor while they are curing during the first 12 to 15 fires. Additional smoke and odor may

## SAFETY INSTRUCTIONS continued...

- be emitted from the barrel components. This should disappear after a short period of time and not occur again. Persons with lung conditions or owners of susceptible domestic pets (such as birds) should take prudent precautions. Open windows and doors as needed to clear smoke and/or odor. Paint discoloration will occur if the stove is over fired.
19. **CLEAN STOVE FREQUENTLY** as soot, creosote and ash may accumulate.
  20. **ALERT ALL PERSONS TO THE HAZARDS OF HIGH SURFACE TEMPERATURES** while stove is in operation – especially young children. Keep away from a hot stove to avoid burns or clothing ignition.
  21. **DO NOT LEAVE SMALL CHILDREN UNSUPERVISED WHEN THEY ARE IN THE SAME ROOM AS THE STOVE.** If small children will be in the same room as the stove during operation, provide a sturdy barrier to keep them at a safe distance from the stove.
  22. Replace any barrel that shows signs of wear, fatigue or has holes in it.
  23. **WARNING: RISK OF FIRE.** Keep stove area clear and free from all combustible materials, gasoline, engine oil, naphtha and other flammable vapors and liquids.
  24. **WHILE TENDING THE FIRE ALWAYS WEAR PROTECTIVE CLOTHING**, fire retardant hearth gloves and eye protection, to prevent burns.
  25. Never operate this stove with the ash or feed doors open. Such actions can result in very dangerous operating conditions.
  26. **DO NOT OVER FIRE THE STOVE.** Over firing will occur if combustion air is uncontrolled as when the ash or feed door is left open during operation. Such actions can result in very dangerous operating conditions. While in operation, keep the feed door closed and secured at all times except while tending the fire
  27. Do not load the fuel to a height or in such manner that it would be hazardous when opening the door.
  28. **NEVER LEAVE THE STOVE UNATTENDED** when the door is open. Always close the door after ignition.
  29. **DO NOT CONNECT TO OR USE IN CONJUNCTION WITH ANY AIR DISTRIBUTION DUCT WORK.**
  30. **A WOOD-BURNING STOVE MUST NEVER BE INSTALLED IN A HALLWAY OR NEAR A STAIRCASE**, as it may block egress in the event of a fire.
  31. **DO NOT INSTALL IN A SLEEPING ROOM. DO NOT INSTALL IN AN ALCOVE OR INSIDE A FIRE-PLACE.**
  32. Install at least one smoke detector on each floor of your home. Detectors should be located close to sleeping areas. Detectors should be located away from the heating appliance to avoid false alarms. Follow manufacturer's placement, installation and maintenance instructions.
  33. **CARBON MONOXIDE (CO) HAZARD.** A buildup of CO fumes is toxic and can be fatal. Carbon Monoxide is a colorless, odorless gas produced during combustion of wood, coal, oil, gas and by other fuel burning appliances. It is important to have a proper draft and adequate replacement air ventilation so fumes are drawn out the chimney. Installed as instructed this stove is designed to be as safe as possible yet it is recommended to **install a CO detector**. Follow the manufacturer's recommendations for proper installation and use. It is recommended to be placed at table-top level (not near the ceiling) to avoid false alarms. Realize that devices other than a stove (i.e. motor exhaust) can trigger CO alarms.  
**If alarm sounds:**
    - Recognize the symptoms of CO poisoning (headaches, nausea & drowsiness).
    - Increase ventilation (open windows & doors).
    - Make sure stove doors and/or lids are closed and secured.
    - Check stove for smoking or puffing (open airflow controls).
    - Check chimney & connector pipe for leaks, blockage or down-draft conditions.
    - Check CO device for false alarm.
  34. Keep power cords, electrical appliances and/or assemblies outside of the clearance area shown in this manual for combustible materials.
  35. Consult your municipal building department or fire officials about restrictions, permits and installation requirements for your area.
  36. For further information on using your stove safely, obtain a copy of the National Fire Protection Association (NFPA) publication, "Using Coal and Wood Stoves Safely" NFPA No. HS-10-1978. The address of the NFPA is Batterymarch Park, Quincy, MA 02269.

**CAUTION: CUT HAZARD. BARREL MAY HAVE SHARP EDGES WHERE OPENINGS HAVE BEEN CUT. DE BURR EDGES, USE PRECAUTIONS AND WEAR ANSI APPROVED SAFETY EQUIPMENT WHEN INSTALLING BARREL STOVE KIT.**

**CAUTION: EXPLOSION HAZARD. DO NOT USE ACETYLENE TORCH TO CUT OPENINGS IN BARREL – SOME BARRELS MAY CONTAIN EXPLOSIVE OR FLAMMABLE GASSES. MAKE SURE BARRELS ARE THOROUGHLY CLEANED BEFORE INSTALLING STOVE KIT.**

# ASSEMBLY INSTRUCTIONS

**NOTICE: Vogelzang International Corp. grants no warranty, stated or implied for the assembly, installation or maintenance of your barrel stove kit and assumes no responsibility of any incidental or consequential damages.**

## TOOLS REQUIRED

Safety Glasses	Metal File
Safety Gloves	Drill: Hand or Electric
Pencil or scribe	1/4" dia. Drill Bit
6 foot Folding Rule or Tape Measure	#2 Phillips Screwdriver
Sabre or Reciprocating Saw with metal cutting blade	10mm Nut Driver or Ratchet with 10mm Socket (for Stove Bolts)
Tin Snips	

**CAUTION: STOVE IS HEAVY. MAKE SURE YOU HAVE ADEQUATE HELP AND USE PROPER LIFTING TECHNIQUES WHEN ASSEMBLING KIT AND WHENEVER MOVING STOVE.**

Refer to diagram and parts lists at back of this manual.

1. Remove parts from inside of carton. Parts include: one damper collar (#1), two leg sets (#2), one door/frame assembly (#3–16) and one hardware pack (#7).
2. Stand barrel on end with plug facing up. Position door between the large and small plugs with the large plug at the 12 o'clock position.  
NOTE: On 30 gallon barrels, use end without plugs for mounting door.
3. Open the feed door and trace around the opening using a scribe or marking pencil.
4. Open the ash door and trace around the opening using a scribe or marking pencil.
5. Remove the door assembly from the barrel end.
6. Cut the opening for the feed door and ash door (fig. 1) using either a sabre saw or a reciprocating saw with a metal blade. De burr opening with metal file.

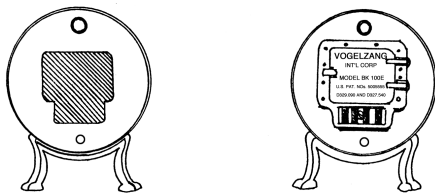

**Fig. 1 – Cut opening in end of barrel, drill mounting holes and install door assembly.**

7. Set the door frame assembly over the newly created holes. Mark and drill the mounting holes using a 1/4" bit. De burr opening with metal file. Attach the assembly using nuts and bolts provided with kit.
8. With the door opening cut, you are now able to get at the inside of the barrel to attach leg assemblies. Center legs so barrel is stabilized and secure legs to barrel.
9. Align damper/collar toward the rear of barrel. Using a scribe or marking tool, trace the throat of the collar onto the barrel top.

## MATERIALS REQUIRED

*(NOTE: The following items are NOT included with your stove)*

- |   |  |
|---|--|
| Steel Barrel(s): Use only 30–55 gal. closed head-style steel barrel(s).   | MSG black or 26 MSG blue steel stove pipe (straight and/or elbow(s) as required).    |
| Flooring Protection: Install on non-combustible (soil or concrete) floor. Non-combustible floor protection must be provided under any connector pipe extending 2" on either side. | 1/2" Sheet Metal Screws.   |
| Chimney Connector Pipe: round 6" dia. minimum 24  | Chimney: Existing 6" Lined Masonry Chimney or 6" Inside Dia. listed Type HT chimney. |
|   | Furnace Cement (manufacturer recommends Rutland Code 78 or equivalent).              |

10. Cut the flue pipe opening using a sabre saw or reciprocating saw. De burr opening with metal file.
11. Reposition the damper collar over the newly created opening. Mark and drill the mounting holes using a 1/4" bit. De burr holes with metal file. Attach the damper collar using nuts and bolts provided with kit.

## Double Barrel Stove Kit Model BK50E

1. After lower barrel has been assembled, place adapter legs on top of bottom barrel. Mark holes, drill and attach.
2. Place second barrel on top of lower barrel.
3. Align barrels, mark, drill and cut opening for damper collar in the bottom of the top barrel to connect to the damper/collar at rear of the lower barrel.
4. Attach damper collar to bottom of top barrel.
5. Align both barrels and place a piece of 6" blue/black stove pipe between rear damper/collars of top and bottom barrels.
6. Secure adapter legs to top barrel.
7. On opposite (front) end of top barrel, mark, cut and attach damper collar for chimney connection (fig. 2).

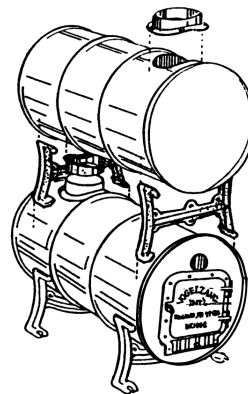

**Fig. 2 – Double Barrel Stove Kit BK50E**

# LOCATING STOVE

Proper clearances must be maintained for adequate air circulation. Adequate ventilation must be provided while operating this stove.

1. The stove must be placed on solid concrete, solid masonry, or similar non-combustible surface.  
**NOTE: WOODEN FLOORING COVERED WITH TILE OR STONE MUST BE CONSIDERED A COMBUSTIBLE SURFACE.**
2. THE STOVE MUST HAVE ITS OWN FLUE. DO NOT CONNECT THIS UNIT TO A CHIMNEY FLUE SERVING OTHER APPLIANCES.
3. After observing the clearances to combustible materials (figure 3 – 5), locate your stove accordingly (figure 3) and carefully place the stove in your selected location. Install stove pipe, elbows, and thimble as required, utilizing either a recently cleaned and inspected, code-approved, 6" masonry chimney with flue liner or a 6" i.d., maximum 64 square inch, listed chimney.
4. Use 6" round black stove pipe. **DO NOT USE GALVANIZED PIPE.** Secure pipe sections with three (3) sheet metal screws in each stove pipe and/or elbow joint to firmly hold the pipe sections together. Screws should be spaced no more than a maximum of 3"/76mm apart.  
**DO NOT CONNECT THIS STOVE TO ANY AIR DISTRIBUTION OR DUCT SYSTEM.**
5. Recheck clearances from the stove, connector stove pipe, and corner clearances using the illustrations (figure 3 – 5) and your local building codes or fire protection ordinances.

**NOTE: DRYWALL FACED WITH BRICK OR STONE MUST BE CONSIDERED A COMBUSTIBLE SURFACE.**

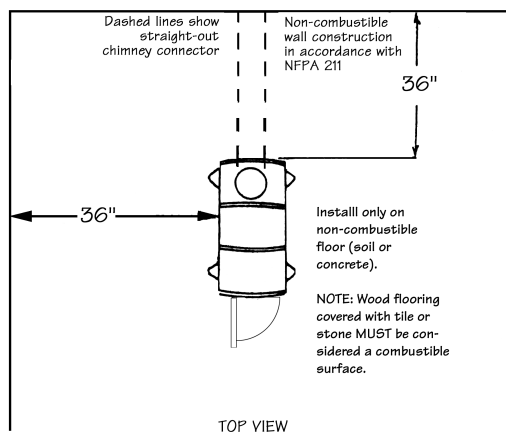

Fig. 3 – Floor Protector Clearances

6. **DO NOT INSTALL THIS STOVE IN A MOBILE HOME, MANUFACTURED HOME, TENT, OR TRAILER—NO EXCEPTIONS! (HUD Federal Standard: 24 CFR Ch.XX)**
7. The clearances provided are minimum dimensions.
8. This stove is **NOT** a UL listed stove.

## MINIMUM CLEARANCES TO COMBUSTIBLE SURFACES

Unit to Sidewall .....	36 inches
Unit to Back wall .....	36 inches
Unit Corner to Wall .....	36 inches
Pipe Connector to Ceiling/Wall .....	18 inches

**CAUTION: KEEP FURNISHINGS AND OTHER COMBUSTIBLE MATERIALS AWAY FROM THE STOVE.**

## CORNER CLEARANCES

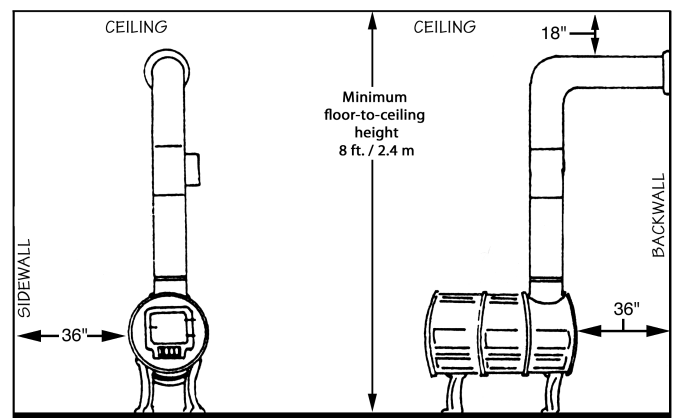
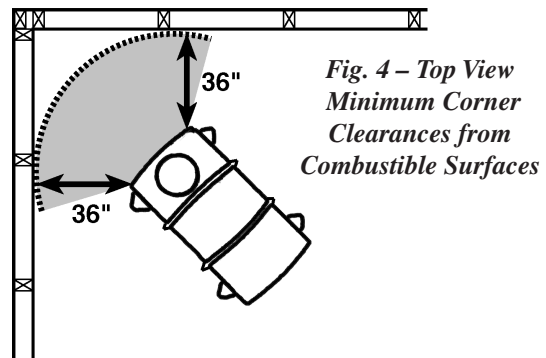

**SOLID NON-COMBUSTIBLE FLOOR (CEMENT OR SOIL) NOTE: SOLID, NON-COMBUSTIBLE FLOOR MUST EXTEND UNDER AND 2" ON EITHER SIDE OF HORIZONTAL RUNS OF CHIMNEY CONNECTOR PIPE. WOOD FLOORS COVERED WITH TILE OR STONE MUST BE CONSIDERED A COMBUSTIBLE SURFACE.**

Fig. 5 – Minimum Clearances

# CONNECTOR PIPE INSTALLATION

**NOTE: CONNECTOR PIPE IS NOT INCLUDED. USE ROUND 6 IN. DIA. MINIMUM 24 MSG (MINIMUM STANDARD GAUGE) BLACK OR 26 MSG BLUE STEEL STOVE PIPE. DO NOT USE GALVANIZED PIPE. TO PURCHASE PIPE, VISIT YOUR LOCAL HARDWARE, HOME OR BUILDING CENTER. SEE "LOCATING STOVE" PAGE 5 FOR ADDITIONAL SPECIFICATIONS.**

Connector pipe is used to make the connection from the final positioning of your stove to an approved chimney. Connector pipe is NOT included as part of the stove. Connector pipe must be 6"/152mm diameter minimum of 24 MSG (minimum standard gauge) black or 26 MSG blue steel stove pipe. Connector pipe is not rated to provide close contact to combustible materials and must have proper clearance from combustible materials as shown in the clearance diagrams on the previous pages. Connector pipe should never be used in place of a chimney. If proper clearances are not observed a house fire could result.

## Installation Instructions

1. The smooth end of the stovepipe fits over the stove flue collar. Secure with three (3) sheet metal screws and seal with stove cement.
2. Horizontal pipe runs must slope upwards towards the chimney at least 1/4"(6.4mm) per foot of horizontal run.
3. You must have at least 18"/457mm of clearance between any horizontal piping and the ceiling.

4. The pipe cannot extend into the chimney flue (figure 6).
5. Secure pipe/elbow sections with three sheet metal screws at each joint to make the piping rigid. Screws should be spaced no more than a maximum of 3"/76mm apart.
6. It is recommended that no more than two (2) 90° bends be used in the stovepipe installation. The use of more than two 90° bends may decrease the amount of draw and possibly cause smoke spillage. Where possible, use only corrugated (non adjustable) elbows. These provide a better seal.
7. The connector pipe must not pass through an attic or roof space, trusses, closet, or any concealed space, floor, ceiling, wall, or combustible construction. (See Chimney Connector Systems & Clearances, page 10.) A manufactured chimney system listed to UL 103 HT must be used from the first penetration of ceiling or wall to the chimney cap. Use components from only one manufacturer – do not mix brands.

Where passage through a wall or partition of combustible construction is desired, the installation shall conform to NFPA 211 (USA).

**WARNING: DO NOT USE A SINGLE-WALL CONNECTOR PIPE AS A CHIMNEY! A HOUSE FIRE COULD RESULT.**

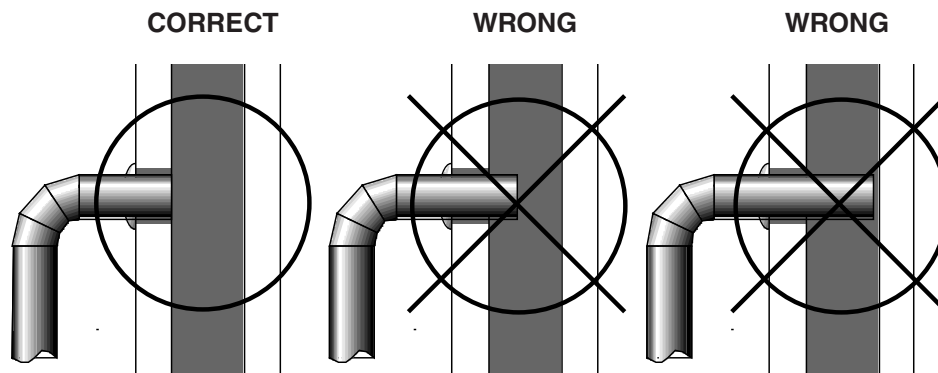

*Fig. 6 – Stovepipe/Flue Connections*

# CHIMNEY CONNECTIONS

The stove must be connected to either a masonry or manufactured metal chimney built and tested to the specifications listed on the previous pages.

Chimneys perform two functions:

1). As a means of exhausting smoke and flue gases which are the result of fuel combustion.

2). The chimney provides “draft” which allows oxygen to be continuously introduced into the appliance, so that proper combustion is possible. This stove relies on natural draft to operate.

**NOTICE: Always provide a source of fresh air into the room where the stove is located. Failure to do so may result in air starvation of other fuel burning appliances and the possible development of hazardous conditions, fire or death.**

**DRAFT: Your stove itself does not create draft. Draft is provided by the chimney.** To achieve proper draft your chimney must meet the three minimum height requirements detailed in figures 8–11. A minimum of 0.05 w.c. (measured in water column) is required for proper drafting to prevent back puffing, smoke spillage, and to maximize performance. Draft must not exceed 0.06 w.c. or unsafe operating conditions may occur. A barometric draft regulator must be installed if draft exceeds 0.06 w.c. (Gauges to measure draft are readily available at stove stores and are economical to rent or purchase.)

Factors such as wind, barometric pressure, trees, terrain and chimney temperature can have an adverse effect on the draft. The manufacturer cannot be held responsible for external factors leading to less than optimal drafting.

Should you have a problem with inadequate draft, you should contact a licensed heating and cooling contractor for assistance in solving the problem.

## IMPORTANT Installation Points

1. Size chimney flue to stove collar. This stove requires a 6” diameter flue.
2. Never connect this unit to a chimney serving another appliance.
3. The chimney must meet all minimum height requirements.
4. Never use a chimney to ventilate a cellar or basement.
5. Contact your local building authority for approved methods of installation and any necessary permits and/or inspections.

## MASONRY CHIMNEY

Chimney must be a code-approved, masonry chimney with flue liner. Before using an existing masonry chimney, clean the chimney, inspect the flue liner and make any repairs needed to be sure it is safe to use. Make repairs before attaching the stove. The connector stove pipe and fittings you will need to connect directly to a masonry chimney are shown in figure 7.

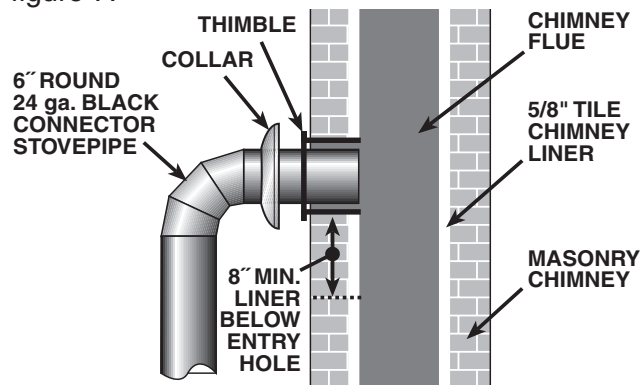

Fig. 7 - Chimney Connection

If the connector stove pipe must go through a combustible wall before entering the masonry chimney, consult a qualified mason or chimney dealer. The installation must conform to local building and fire codes and latest edition of NFPA 211.

If there is a cleanout opening in the base of the chimney, close it tightly.

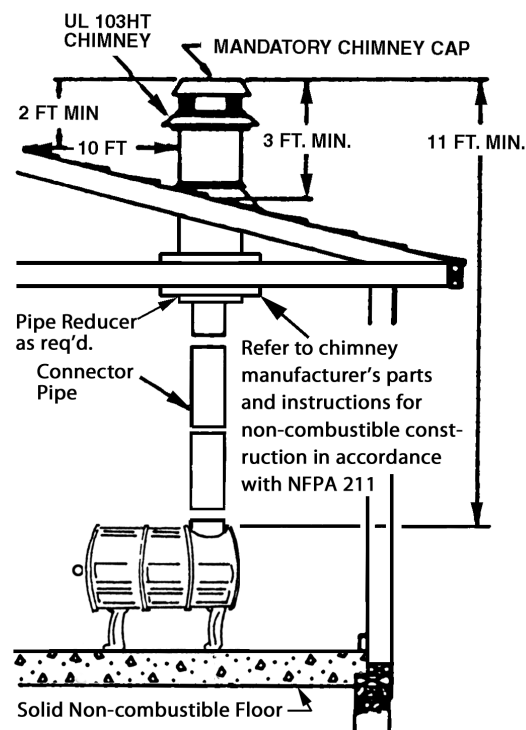

Fig. 8 - Chimney Construction Through Attic Space

# CHIMNEY CONNECTIONS *continued ...*

## MANUFACTURED CHIMNEY

REFER TO CHIMNEY AND CHIMNEY CONNECTOR MAKER'S INSTRUCTIONS FOR INSTALLATION AND USE.

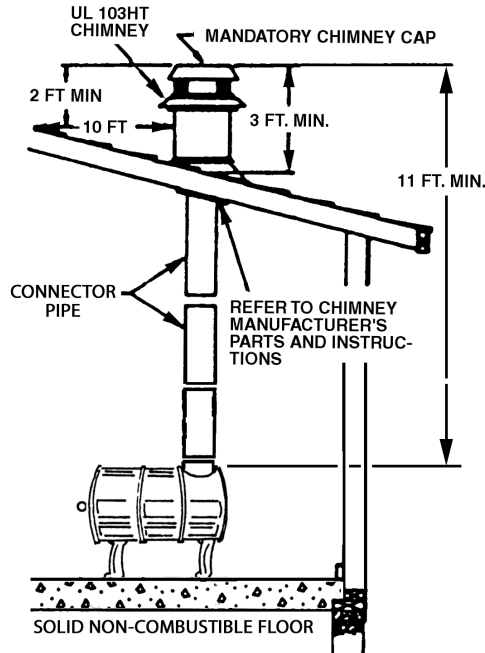

Fig. 9 - Chimney Construction Through Roof

Use only a 6" diameter manufactured chimney system listed to UL 103 HT. Chimney made to this listing is High Temperature rated to 2100 degrees Fahrenheit. Use chimney from only one manufacturer. Never mix brands. Carefully follow the chimney manufacturer's stated requirements and clearances. Use the chimney manufacturer's attic guards, roof supports, flashing and fire stops when passing through a ceiling. Use a listed

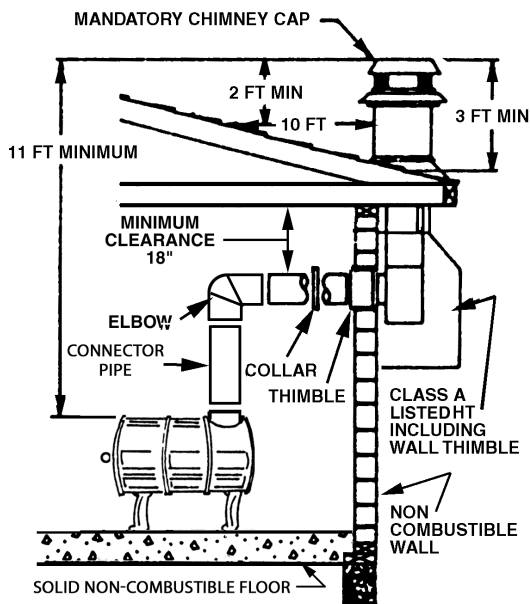

Fig. 10 - Chimney Connection to Firebox Through Noncombustible (Masonry) Wall

thimble when passing through a combustible wall. Do not use makeshift compromises during installation.

**WARNING: DO NOT USE SINGLE WALL CONNECTOR PIPE AS A CHIMNEY - A HOUSE FIRE COULD RESULT.**

When using a pre-existing chimney, have it's condition and installation inspected before using. Make sure that the chimney meets all of the UL rating requirements listed above. Be aware that not all manufactured chimney is of the UL 103 HT type.

NOTE: It is recommended that you contact a licensed heating and cooling contractor (consult your local yellow pages) for chimney installation.

Manufactured chimney with the proper required UL listing is available from most home centers, hardware stores, and HVAC supply stores.

If you have access to the internet, you may wish to view chimney manufacturers' information on-line. See, [www.duravent.com](http://www.duravent.com), [www.selkirkinc.com](http://www.selkirkinc.com), or [www.mtffab.com](http://www.mtffab.com).

## VENTING TO EXISTING FIREPLACE

In some instances, people desire to convert an existing fireplace for stove use. Usually, safe connection to an existing masonry chimney requires more work than using a prefabricated chimney. The existing fireplace must be closed and sealed at the damper with high-temperature caulk, ceramic wool, or furnace cement. Prior to installation, clean and inspect the existing flue and smoke shelf. Installation should be designed so the system can be dismantled for periodic cleaning and inspection. Before conversion, make sure the existing chimney is structurally sound, the chimney incorporates a flue liner and make sure it is in good condition. (A flue liner consists of clay tile that protects the brickwork of a chimney. If a chimney does not have a liner, or it is damaged, have it relined by a professional. **DO NOT USE a chimney that is unlined or damaged!**) If you have any question regarding the condition of the chimney, consult a qualified licensed contractor, qualified engineer, competent mason, certified Chimney Sweep, or a knowledgeable inspector. Consult your insurance company if you cannot find a qualified expert.

**CAUTION: NOT ALL FIREPLACE CHIMNEYS ARE SUITABLE FOR CONVERSION TO ACCOMMODATE CONNECTION TO A WOOD STOVE. CHECK WITH A QUALIFIED EXPERT.**

Many prefabricated fireplaces are of the "zero-clearance fireplace" category. These consist of multi layered metal construction. They are designed with enough insulation and/or air cooling on the base, back and sides so they can be safely installed in direct contact with combustible floors and walls. Although many prefabricated fireplaces carry

*continued on next page*



## CHIMNEY CONNECTIONS *continued ...*

endorsements from nationally recognized organizations for use as fireplaces, they have not been tested for connection to wood stove heaters. Connecting a stove to such a device will void the manufacturer's warranty.

Venting a stove directly into a fireplace does not meet code and should not be attempted. The stove warranty will be void with such an installation. Do not create a hazard in your home by connecting in this manner.

### FIREPLACE INSTALLATION

**NOTE: DO NOT ATTEMPT TO ROUTE THE CHIMNEY CONNECTOR PIPE THROUGH THE THROAT OF THE FIREPLACE.** Directly connecting the stovepipe into the existing masonry chimney (figure 11 "Type A" Fireplace Conversion) of the fireplace is the ONLY approved method of installation. If the chimney is behind a combustible wall, you must use an approved wall pass-through system to gain access to the chimney. This is a complicated and involved process and to ensure safety should only be done by a qualified installer.

1. An entry hole must be cut through the masonry and tile liner with minimal damage to the liner. At least 8" of liner must remain below the entry position. When locating the stove and stovepipe, all minimum clearances must be observed from combustible surfaces including mantels, combustible trim work, ceilings and walls. Positioning the center of the stove pipe entry into the chimney 24" below the ceiling should insure proper clearance for a 6" stovepipe.
2. Install a fire clay (5/8" minimum thickness) thimble. Make sure the thimble is flush with the inner surface of the chimney liner and does not protrude into the flue (see figure 8 on page 6).

3. Secure the thimble with refractory mortar. The thimble should be surrounded by 12" of solid unit masonry brickwork or 24" of stone.
4. Install the stovepipe into the thimble as far as possible without extending past the flue lining (see figures 6 & 7 on pages 6 & 7).
5. A small airspace (about 1/2") should remain between the stovepipe and thimble to allow for expansion of the pipe. Seal this airspace with high-temperature caulking or ceramic wool.
6. Secure and seal the damper in the closed position using high-temp caulking, ceramic wool, or furnace cement. Also check to see if the chimney has a cleanout. If it does, make sure it is closed and sealed as well. A leaky cleanout will greatly reduce draft efficiency.

If you have any questions regarding venting your stove, contact the manufacturer or contact the National Fire Protection Association (NFPA) and request a copy of the latest editions of NFPA Standard 211 and NFPA Standard 908. Their address is:  
Battery March Park, Quincy, MA 02269.

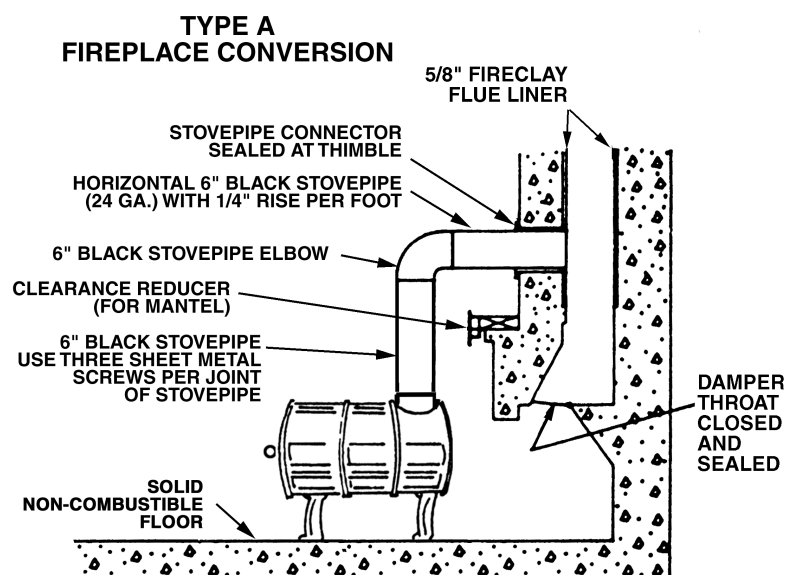
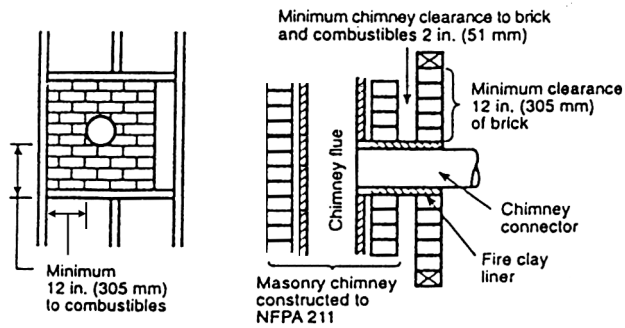

Fig. 11 - Fireplace Conversion

# CHIMNEY CONNECTOR SYSTEMS & CLEARANCES



## A. Brick Masonry

Minimum 3.5" (89mm) thick brick masonry all framed into combustible wall with a minimum of 12" (305mm) brick separation from clay liner to combustibles. The fireclay liner shall run from outer surface of brick wall to, but not beyond, the inner surface of chimney flue liner and shall be firmly cemented in place.

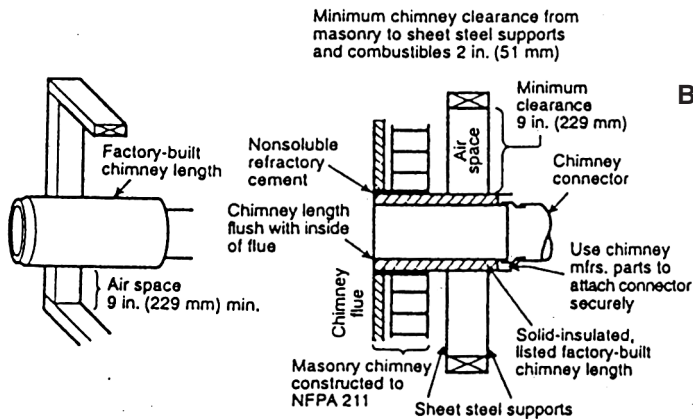

## B. Insulated Sleeve

Solid-insulated, listed factory-built chimney length of the same inside diameter as the chimney connector and having 1" (25.4mm) or more of insulation with a minimum 9" (229mm) air space between the outer wall of the chimney length and combustibles.

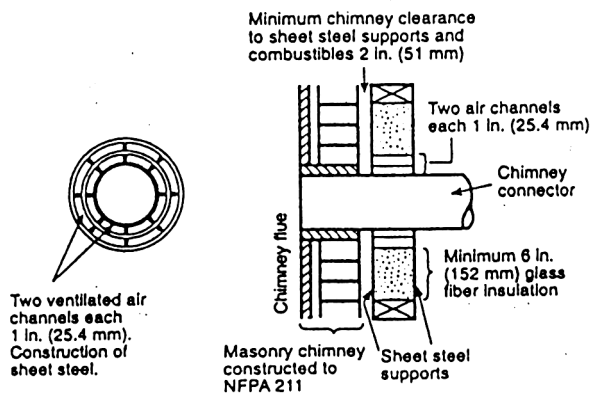

## C. Ventilated Thimble

Sheet steel chimney connector, minimum 24 gauge in thickness, with a ventilated thimble, minimum 24 gauge in thickness, having two 1" (25.4mm) air channels, separated from combustibles by a minimum of 6" (152mm) of glass fiber insulation. Opening shall be covered, and thimble supported with a sheet steel support, minimum 24 gauge in thickness.

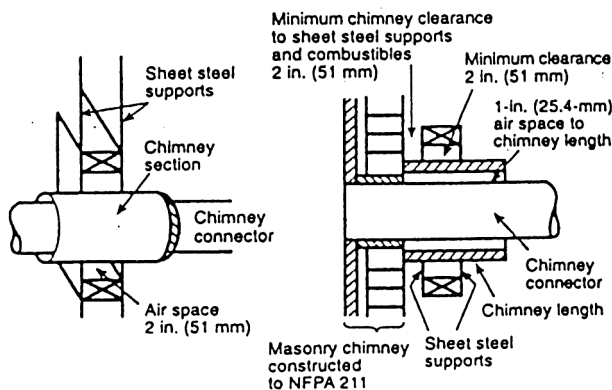

## D. Chimney Section Pass-through

Solid insulated, listed factory-built chimney length with an inside diameter 2" (51mm) larger than the chimney connector and having 1" (25.4mm) or more of insulation, serving as a pass-through for a single wall sheet steel chimney connector of minimum 24 gauge thickness, with a minimum 2" (51mm) air space between the outer wall of chimney section and combustibles. Minimum length of chimney section shall be 12" (305mm) chimney section spaced 1" (25.4mm) away from connector using sheet steel support plates on both ends of chimney section. Opening shall be covered, and chimney section supported on both sides with sheet steel support securely fastened to wall surfaces of minimum 24 gauge thickness. Fasteners used to secure chimney section shall not penetrate chimney flue liner.

# OPERATING INSTRUCTIONS

## CAUTION: HOUSE FIRE HAZARDS

- DO NOT STORE WOOD ON FLOOR PROTECTOR, UNDERNEATH STOVEPIPE, OR ANYWHERE WITHIN MINIMUM CLEARANCES FROM COMBUSTIBLE SURFACES SPECIFIED FOR THIS STOVE.
- OVER FIRING MAY CAUSE A HOUSE FIRE. YOU ARE OVER FIRING IF A UNIT OR CHIMNEY CONNECTOR GLOWS RED.

## OPERATING SAFETY PRECAUTIONS

1. NEVER OVER FIRE THIS STOVE BY BUILDING EXCESSIVELY HOT FIRES AS A HOUSE/BUILDING FIRE MAY RESULT. YOU ARE OVER FIRING THE STOVE IF UNIT OR STOVEPIPE BEGINS TO GLOW OR TURN RED.
2. NEVER BUILD EXTREMELY LARGE FIRES IN THIS TYPE OF STOVE AS DAMAGE TO THE STOVE OR SMOKE LEAKAGE MAY RESULT
3. UNIT IS HOT WHILE IN OPERATION. KEEP CHILDREN, CLOTHING, AND FURNITURE AWAY. CONTACT MAY CAUSE SKIN BURNS. DO NOT TOUCH THE STOVE AFTER FIRING UNTIL IT HAS COOLED.
4. PROVIDE AIR INTO THE ROOM FOR PROPER COMBUSTION.
5. INSPECT STOVEPIPE EVERY 60 DAYS. REPLACE IMMEDIATELY IF STOVEPIPE IS RUSTING OR LEAKING SMOKE INTO THE ROOM.

## WARNING: EXPLOSION HAZARD

- DO NOT USE CHEMICALS OR FLUIDS TO START THE FIRE.
- NEVER USE GASOLINE, GASOLINE-TYPE LANTERN FUEL, KEROSENE, CHARCOAL LIGHTER FLUID, OR SIMILAR LIQUIDS TO START OR 'FRESHEN-UP' A FIRE IN THIS HEATER. KEEP ALL SUCH LIQUIDS WELL AWAY FROM THE HEATER WHILE IT IS IN USE.
- KEEP ALL FLAMMABLE LIQUIDS, ESPECIALLY GASOLINE, OUT OF THE VICINITY OF THE STOVE — WHETHER IN USE OR IN STORAGE.

## This stove is designed to burn WOOD FUEL ONLY.

Hardwood, 18" to 28" should be split and air dried (seasoned), for 6 months to obtain maximum burning efficiency. Wood should be stored in a dry, well ventilated area.

**CAUTION: USE SOLID WOOD MATERIALS ONLY. DO NOT BURN GARBAGE OR FLAMMABLE FLUIDS. DO NOT USE COAL. USE OF COAL OR CHARCOAL CAN DAMAGE THE STOVE COMPONENTS.**

**NOTE: BUILD SIX (6) SMALL FIRES UPON INITIAL FIRING TO TEMPER BARREL STOVE AND SEASON CAST IRON COMPONENTS.**

**NOTE: A 2" LAYER OF SAND OR A LAYER OF FIREBRICK SHOULD BE USED AS BOTTOM INSULATION IN THE BARREL STOVE. A CAST IRON OR STEEL GRATE (55G) MAY BE USED IN CONJUNCTION WITH THE BOTTOM INSULATION.**

## LIGHTING

1. Fully open damper/collar and spin draft below door to provide maximum air draft.
2. Open the feed door and place several wads of crushed paper in the firebox.
3. Lay small stacks of kindling on the paper to start the fire.
4. Light the paper and kindling, close the door and secure tightly.
5. Add fuel after fire is burning briskly. Use care not to smother the kindling fire when adding wood. Close the door and secure tightly.
6. Adjust spin draft and flue damper/collar for proper combustion. Periodically check fire to assure proper firing. The more closed the spin draft is set, the lower and slower the fire will burn. The more open, the faster and hotter the fire will burn. Do not over fire the stove.
7. NEVER build extremely large fires in this type of barrel stove as damage to the barrel stove or smoking may result.
8. If you have too much draft, then regulate the draft with the 6" cast iron stove pipe damper in the damper/collar.
9. DO NOT TOUCH the barrel stove after firing until it has cooled.

*continued on next page*

## OPERATING INSTRUCTIONS *continued ...*

10. **NEVER OVER FIRE** this barrel stove by building excessively hot fires as a house/building fire may result.
11. **Inspect stove pipe and barrel every 60 days.** Replace immediately if there is rusting or smoke leaking into the room.
12. If barrel stove begins to glow or turn red, you are **over firing** the barrel stove. Immediately adjust spin draft to the **closed** position and turn 6" cast iron damper to a fully **closed** position. This will limit the amount of air being allowed into the barrel and will reduce the burn rate of the fire.

### ADDING FUEL

Add small amounts of fuel each hour or so instead of piling large quantities of fuel at one time. This will insure a more complete combustion process and less buildup of tars, soot, or creosote will occur in the chimney.

1. Always open draft damper before opening the feed door.
2. When adding fuel be careful not to smother the fire.
3. Close the feed door and secure tightly.
4. Adjust the damper and spin draft control.
5. Empty ashes regularly. Do not allow ashes to pile up higher than lower edge of the spin draft.
6. Properly dispose of hot ashes (see Safety Instructions, item #14 on page 2.)
7. Do not over fire the stove (see step #12 above).

### OPERATING SAFETY PRECAUTIONS

**NEVER OVER FIRE THIS STOVE BY BUILDING EXCESSIVELY HOT FIRES AS A HOUSE/BUILDING FIRE MAY RESULT. YOU ARE OVER FIRING THE STOVE IF STOVE OR STOVEPIPE BEGINS TO GLOW OR TURN RED.**

**NEVER BUILD EXTREMELY LARGE FIRES IN THIS TYPE OF STOVE AS DAMAGE TO THE STOVE OR SMOKE LEAKAGE MAY RESULT.**

**STOVE IS HOT WHILE IN OPERATION. KEEP CHILDREN, CLOTHING, AND FURNITURE AWAY FROM HOT STOVE. CONTACT MAY CAUSE SKIN BURNS. DO NOT TOUCH THE STOVE AFTER FIRING UNTIL IT HAS COOLED.**

**PROVIDE AIR INTO THE ROOM FOR PROPER COMBUSTION.**

**INSPECT STOVE AND PIPE EVERY 60 DAYS. REPLACE IMMEDIATELY IF STOVEPIPE IS RUSTING OR LEAKING SMOKE INTO THE ROOM.**

**CAUTION: SLOW BURNING FIRES AND EXTENDED USE MAY CAUSE EXCESSIVE CREOSOTE BUILDUP. IGNITION OF CREOSOTE BUILDUP OR OVER FIRING MAY CAUSE A CHIMNEY FIRE. CHIMNEY FIRES BURN EXTREMELY HOT AND MAY IGNITE SURROUNDING MATERIALS. IN CASE OF A CHIMNEY FIRE IMMEDIATELY LEAVE THE BUILDING AND CALL THE FIRE DEPARTMENT FROM A SAFE LOCATION.**

### CREOSOTE – FORMATION AND NEED FOR REMOVAL

**CAUTION: RISK OF FIRE** When wood is burned slowly, it produces tar and other organic vapors, which combine with expelled moisture to form creosote. The creosote vapors condense in the relatively cool chimney flue of a slow-burning fire. As a result, creosote residue accumulates on the flue lining. When ignited this creosote makes an extremely hot fire.

**The chimney connector, heat transfer barrel and chimney should be inspected at least once every two months during the heating season to determine if a creosote buildup has occurred.**

**If creosote has accumulated (3mm or more) it should be removed to reduce the risk of a chimney fire.**

Failure to remove creosote may result in ignition and may cause a house/building fire. Creosote may be removed using a chimney brush or other commonly available materials from your local hardware retailer.

Chimney fires burn very hot. If the unit or chimney connector should glow red, reduce the fire by closing the inlet air control and immediately call the fire department.

**CAUTION: A CHIMNEY FIRE MAY CAUSE IGNITION OF WALL STUDS OR RAFTERS WHICH WERE ASSUMED TO BE A SAFE DISTANCE FROM THE CHIMNEY. IF A CHIMNEY FIRE HAS OCCURRED, HAVE YOUR CHIMNEY INSPECTED BY A QUALIFIED EXPERT BEFORE USING AGAIN.**

A fire in the firebox may be smothered by pouring a large quantity of coarse salt, baking soda, or cool ashes on top of the fire.

### PREVENTING CREOSOTE BUILDUP

1. Creosote will inevitably form in your chimney and connector pipe. Following these steps will help reduce the rate of build up.

## MAINTENANCE & SERVICE HINTS

2. **BURN ONLY SEASONED WOOD** that has dried for at least one year. (<20% humidity by weight)
3. Burn hardwood rather than softwood. Hardwood is denser or heavier wood and burns hotter.
4. Do not attempt to burn (or mix in) green or wet wood. The use of green or wet wood will cause a rapid build up of creosote. Wood that hisses, sizzles and blackens without igniting in five minutes must be considered too wet to burn.
5. Do not attempt to extend the burn time by using wet wood. Not only does burning wet wood rapidly build up creosote, but it reduces the heat output by up to 25 percent.
6. Do not load more than  $\frac{1}{4}$  to  $\frac{1}{2}$  of the fuel capacity at one time. Loading too much wood at once will cause excessive smoke which contains creosote. Mature fires or coals produce very little creosote-producing smoke.
7. Establish a routine for the handling of fuel, firing, and operating the stove. Check daily for creosote build up until experience shows how often you need to clean for safe operation. Be aware that the hotter the fire, the less creosote is deposited and even though monthly cleanings may be enough in the colder months, weekly cleanings may be necessary in mild weather.

**WARNING: IN CASE OF CHIMNEY FIRE**

- (1) **CLOSE SPIN DRAFT & FLUE DAMPER CONTROLS**
- (2) **GET OUT OF THE HOUSE**
- (3) **CALL THE FIRE DEPARTMENT.**

**IF A CHIMNEY FIRE HAS OCCURRED, HAVE YOUR CHIMNEY INSPECTED BY A QUALIFIED EXPERT BEFORE USING AGAIN.**

**ASH DISPOSAL** – Do not allow ashes to accumulate higher than the optional grate. Dispose of properly. (See Safety Instructions #14, page 2.)

**CHIMNEY DRAFT** – Draft is a function of the chimney, not the stove — do not expect the stove to draw. Smoke spillage into the house or excessive buildup of condensation or creosote in the chimney are warnings that the chimney is NOT functioning properly. Correct the problem before using the stove. Following are some possible causes for improper draft.

1. The connector stovepipe may be pushed into the chimney too far, stopping the draft.
2. If the chimney temperature is too cool, water will condense in the chimney and run back into the stove. Creosote formation will be rapid and may block the chimney. Operate the stove at a fire level high

enough to keep the chimney warm to prevent condensation from forming.

3. If the fire burns well but sometimes creates excess smoke or burns slowly, it may be caused by the chimney top being lower than another part of the house or a nearby tree. The wind blowing over a house or tree, falls on top of the chimney like water over a dam, beating down the smoke. The top of the chimney should be at least three (3) feet above the roof and be at least two (2) feet higher than any point of the roof within ten (10) feet.

**CHIMNEY INSPECTIONS** – The chimney connector and chimney should be inspected **at the beginning** of and **at least twice a month during** the heating season to determine if a creosote buildup has occurred. A log for recording inspections & cleanings is included on page 15 for your convenience.

# ORDERING PARTS - BK150E BARREL STOVE KIT

When ordering missing or replacement parts, always give the **Model Number** of the stove, **Part Number**, and **Part Description**. Use the illustration and parts list provided to identify parts. Contact us at **616-396-1911** to order parts.

Ref. No.	Part No.	Description	Qty.
1	DC100	Damper/Collar.....	1
2	150-2	Leg Assembly .....	2
3	150-3	Door Pin.....	2
4	150-4	Door Latch .....	1
5	150-5	Cool Touch Ball Knob.....	1
6	150-6	Door Bracket.....	1
7	150-7	Hardware Bag.....	1
11	150-11	Door Frame.....	1
12	150-12	Door.....	1
13	GK-14	Door Gasket.....	1
14	GK-14	Spin Dial Door Gasket .....	1
15	150-15	Spin Dial .....	2
16	150-16	Spin Dial Frame .....	1
17	150-17	Shoulder Bolt.....	2

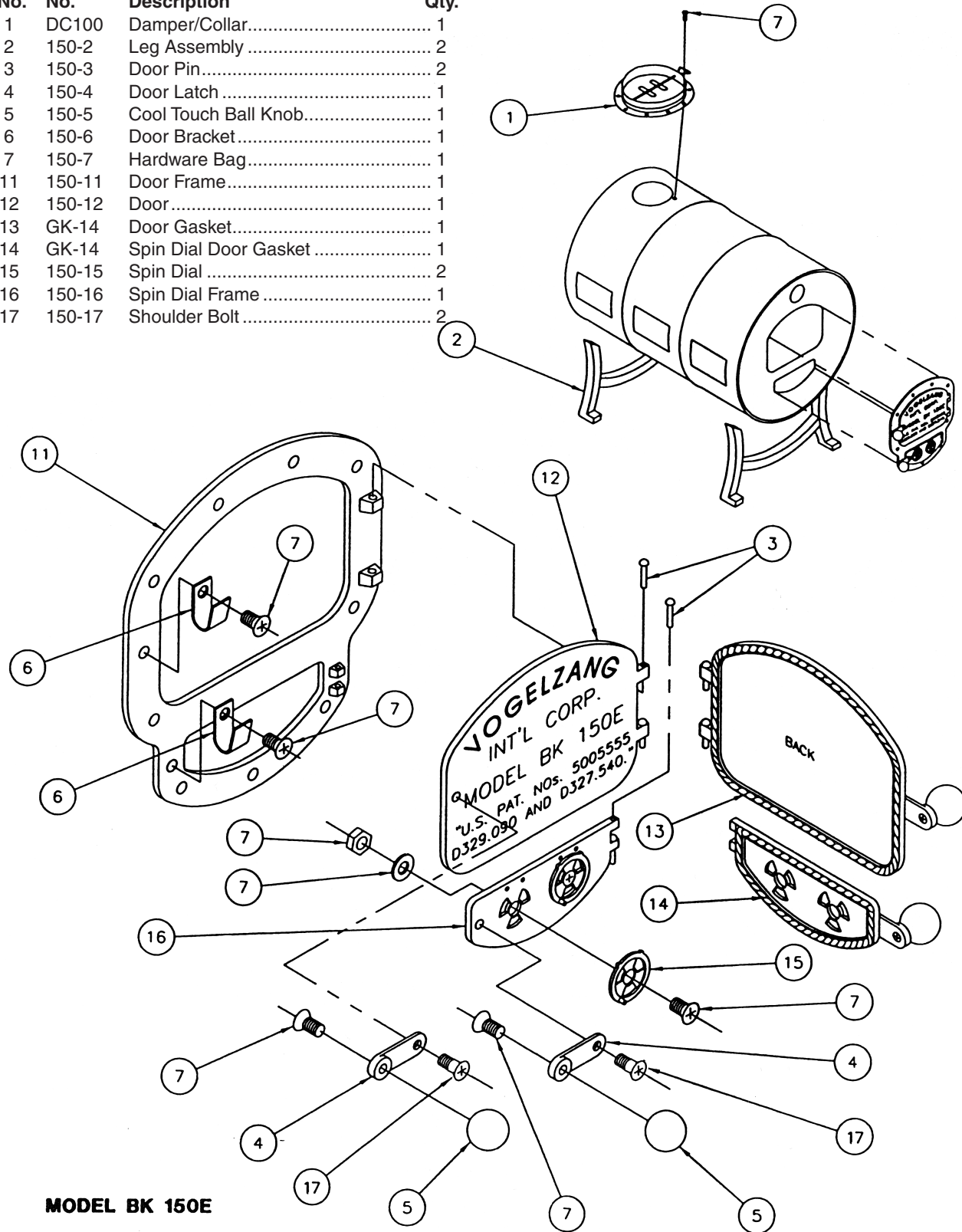

# **CHIMNEY & STOVE MAINTENANCE LOG**

The chimney connector and chimney should be inspected **at the beginning** of and **at least twice a month during** the heating season to determine if a creosote buildup has occurred. Use this chart to record inspection & maintenance service to help schedule necessary service..

DATE OF SERVICE	PERFORMED BY	DESCRIPTION

---

This Vogelzang heating appliance is safe when installed properly and will provide you with years of service. However, always exercise good judgement when you are using this stove. You are dealing with FIRE! Fire is inherently dangerous and must be treated with respect. Stay warm and in good health!

Respectfully yours,

***Steve Vogelzang***

Proprietor

**DO NOT INSTALL THIS KIT STOVE IN A  
MOBILE HOME, MANUFACTURED HOME,  
TRAILER OR TENT — *NO EXCEPTIONS!***

**COMPANY TESTIMONY:**

**“FOR GOD SO LOVED THE WORLD THAT HE GAVE HIS ONLY BEGOTTEN SON, THAT WHOEVER BELIEVES IN HIM SHALL NOT PERISH BUT HAVE ETERNAL LIFE”**

**JOHN 3:16**

**MADE IN CHINA**

---

**VOGELZANG**

*International* CORPORATION



Vogelzang International Corporation  
400 West 17th Street  
Holland, Michigan 49423  
www.vogelzang.com  
Phone: 1-616-396-1911  
Fax: 1-616-396-1971